

Process Simulation & Optimization

Computer Aided Process Modelling & Optimization

PROCESS SIMULATION

- Thermophysical Properties
- Chemical Reactions & Kinetics
- Unit Operations
- Environmental Data
- Safety & Constraint Data

DYNAMICS

- Controller Tuning
- Disturbance Rejection

OPTIMIZATION

- Minimizing Cost
- Maximizing Throughput
- Planning & Scheduling

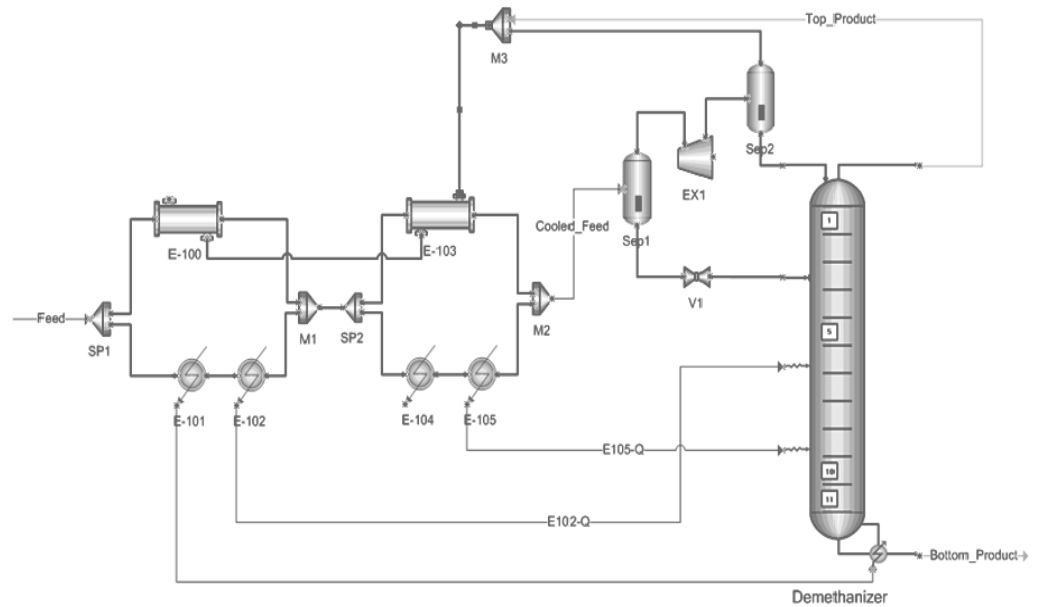

Retaining Competitiveness

To remain competitive in the oil, natural gas, pulp and paper and other processes requires good modelling and powerful optimization algorithms. Simulation and optimization can lead to non-obvious strategies delivering high yields with the lowest possible capital and operating costs. However to reach this stage, one needs good models, a good dynamic simulation platform and the ability to explore the plethora of possibilities in a systematic and efficient way.

Simulation

Process simulation is a model-based representation of chemical, physical, biological and other technical processes and unit operations in software. Basic prerequisites are good internal physical property and unit operation libraries, so that the user can easily construct a process flow diagram of their own particular plant.

Software

Process simulation software describes processes in flow diagrams where unit operations are positioned and connected by product streams. The software has to solve the mass and energy balance to find a stable operating point.

The goal of process simulation is to find out conditions in the plant in parts that you cannot easily directly measure. This information could be used for example for better control.



Process Simulation & Optimization

Computer Aided Process Modelling & Optimization

MORE INFORMATION

For more information on any of our products or services please contact the centre directors:

Professor Brent Young
b.young@auckland.ac.nz
+64 9 923 5606

Associate Professor David Wilson
diwilson@aut.ac.nz
+64 9 921 9999 ext 8732

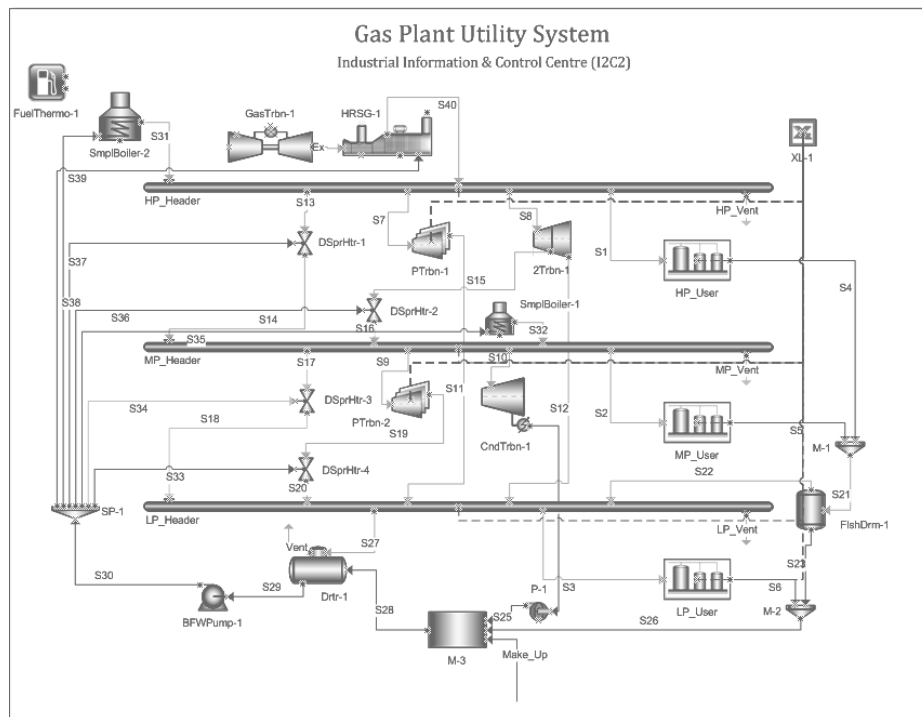

Optimization

Process optimization is the discipline of adjusting a process so as to optimize a specific performance objective without violating safety and operational constraints. The I²C² has recently completed a significant steam utility optimization project for a major international oil and gas client.

The project involved building and adapting process models for steam generators, boilers, gas turbines and condensers and interfaced these models with the client's in-house process simulation software.

Case Studies

- VMGSim development and natural gas processing in Australia (Wesfarmers, Plexal Group, SeaNG and Refrigeration Engineering) and New Zealand (ITNZ, Greymouth Petroleum and Todd Energy).
- Steam and utilities including geothermal in New Zealand (Top Energy, Mighty River Power) and South East Asia (PETRONAS).

Industrial Information & Control Centre

The Industrial Information and Control (I²C²) is a joint collaboration between AUT and the University of Auckland and was established in 2007. Our team is multidisciplinary group of chemical, mechanical, and electrical engineers with backgrounds from pulp and paper to dairy, aluminium and biotechnology.

I²C² SERVICES AVAILABLE

- System Modelling
- Software Design
- APC Tuning & Assessment
- Onsite Training
- Software Installation and Setup
- Technical Support